

LinearChain with pitch 25



D5-213e2/09.05

Subject to technical changes

2 LinearChain with pitch 25 mm

2.1 Type 25 PS (steel)

2.1.1 Technical data

- max. push force (for 0,5 meter of chain unguided, load guided):3.000 N
- weight per meter:..... 2,5 kg
- number of links per meter: 40

2.1.2 Dimensions

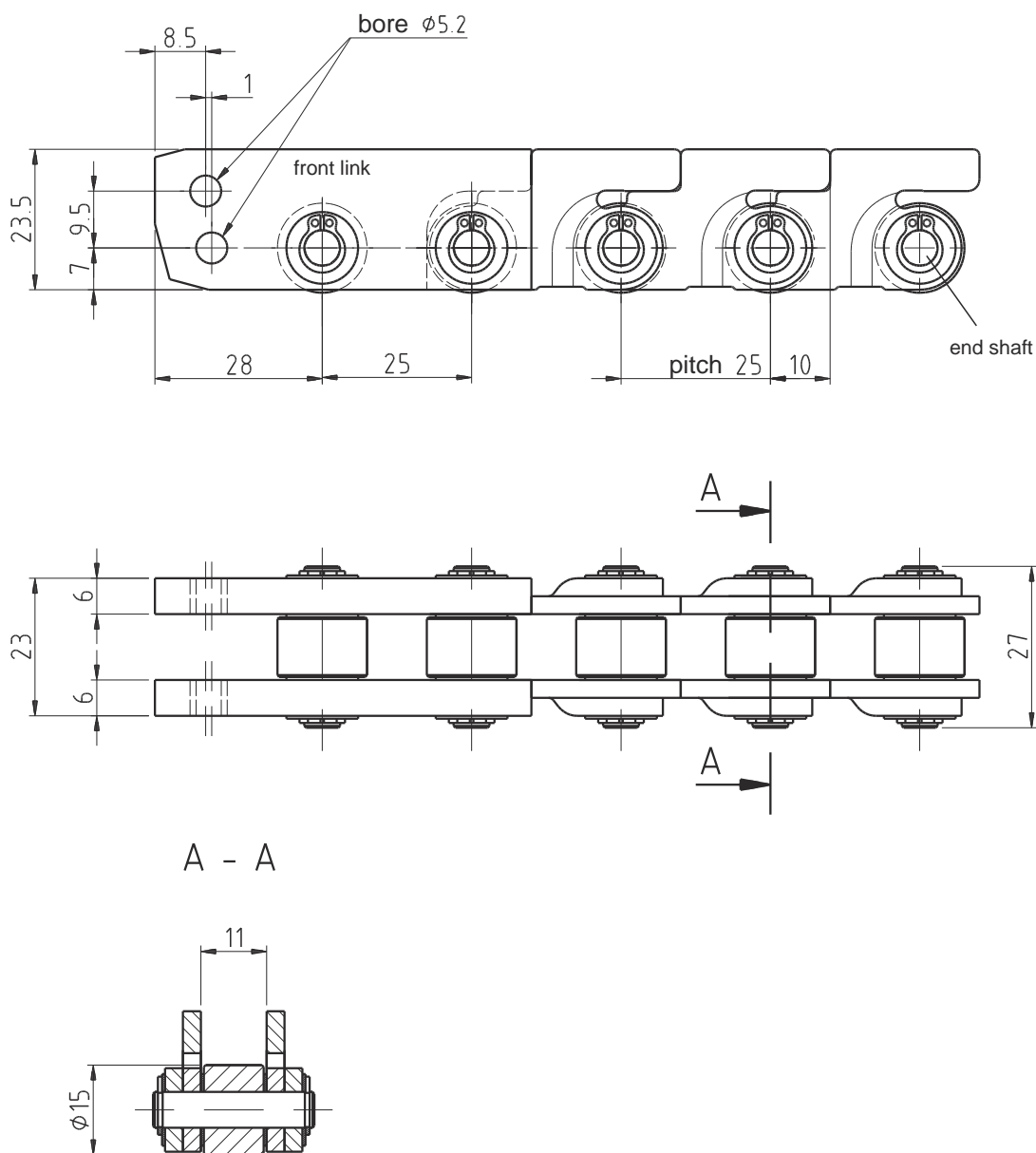

D5-214e3/02.09

Subject to technical changes

Type 25 PS

2.1.4 Assembly of the standard chain link 5-0254-100.00

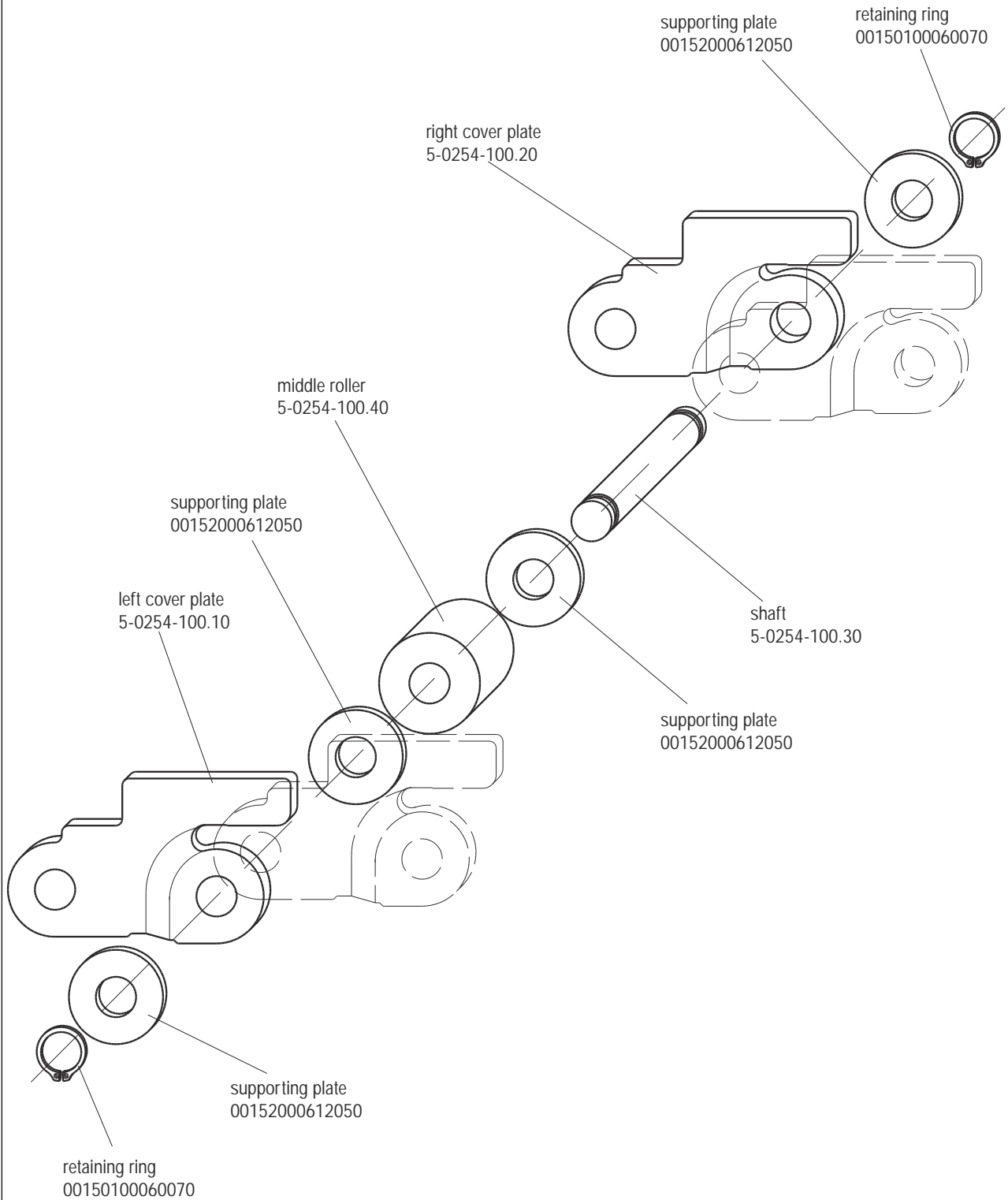

Subject to technical changes

2.2 Type 25 PSG (steel)

2.2.1 Technical data

- max. push force (for 0,5 meter of chain unguided, load guided):3000 N
- weight per meter:..... 3 kg
- number of links per meter: 40

2.2.2 Dimensions

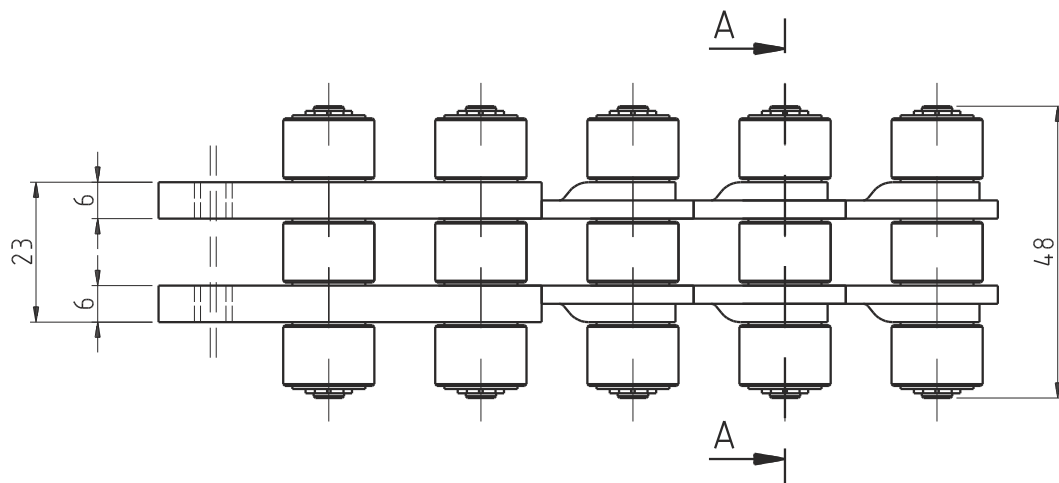
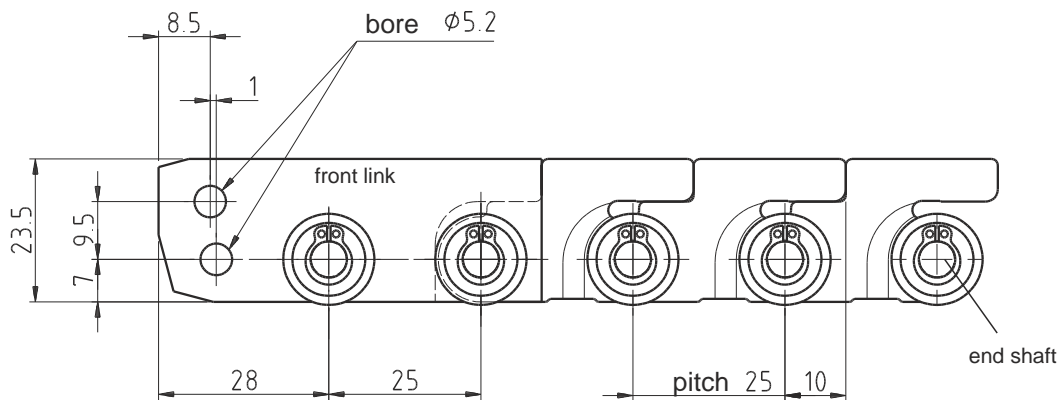

2.2.3 Guiding rail

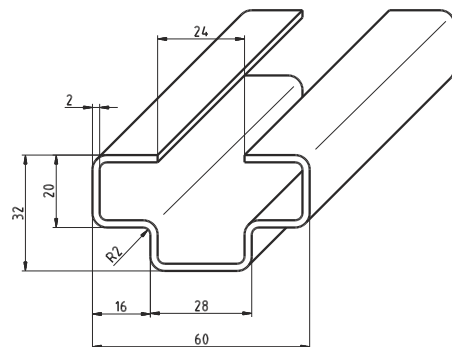
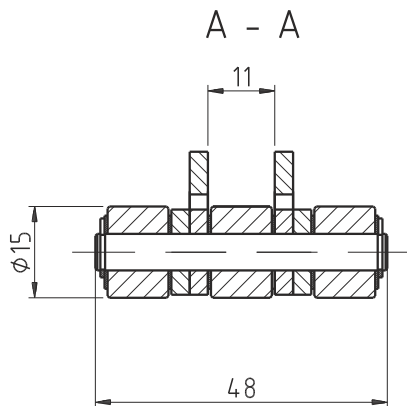

Type 25 PSG

2.1.4 Assembly of the standard chain link 5-0255-100.00

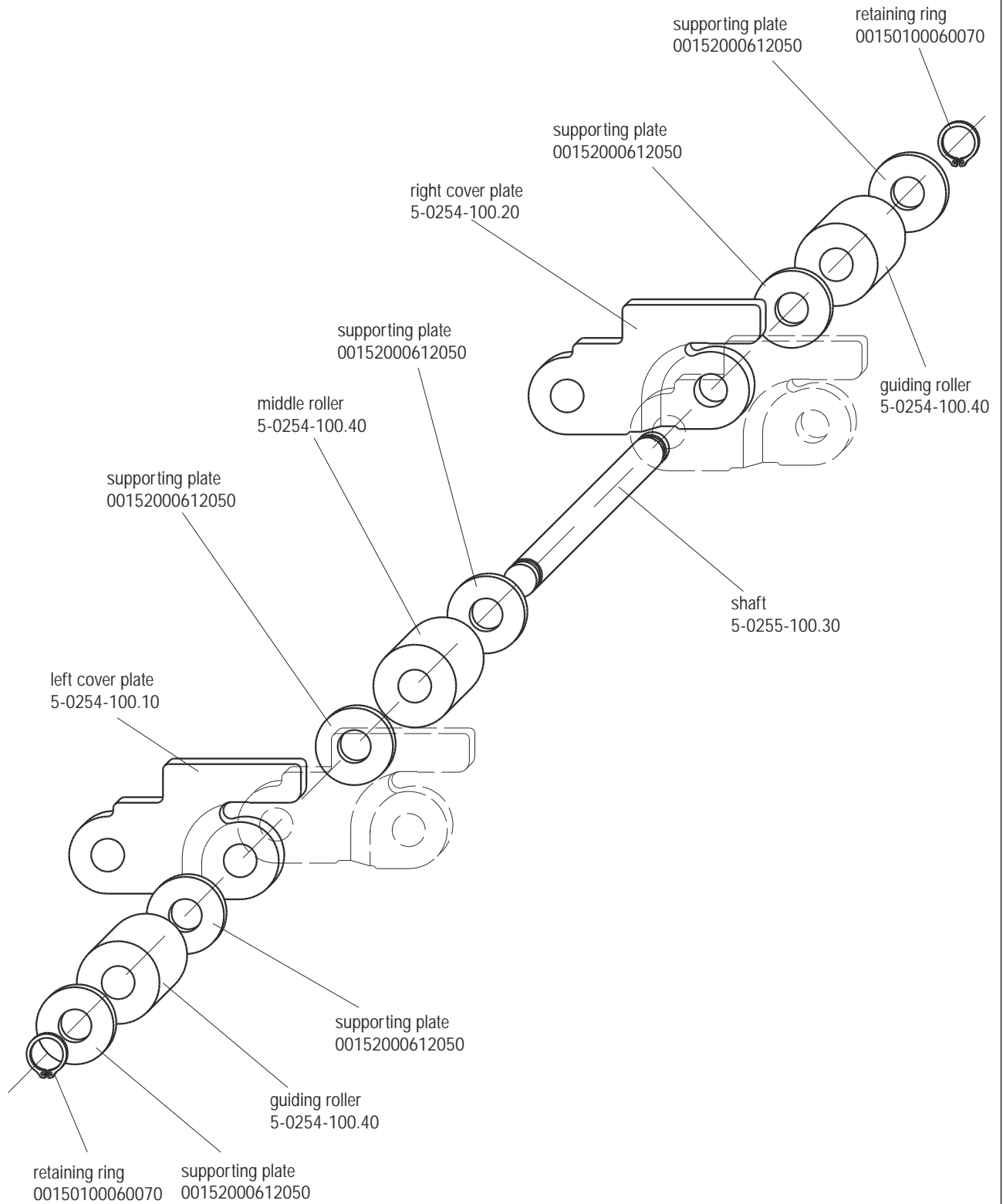

D5-217e2/09.05

Subject to technical changes