

Mini 01



Subject to technical changes

Framo Morat GmbH & Co. KG
Höchst 7 • D-79871 Eisenbach

Tel.: +49 (0) 7657 / 88-0
Fax: +49 (0) 7657 / 88-333

www.framo-morat.com
info@framo-morat.com

Dimensions options

[mm]

Brake or
Encoder or
Potentiometer

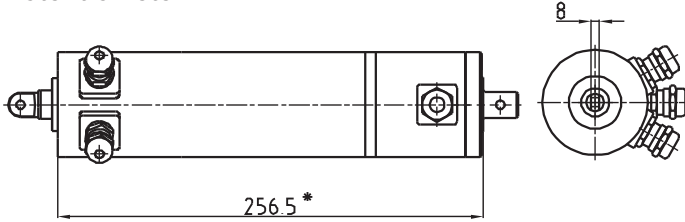

Force dependent shut off

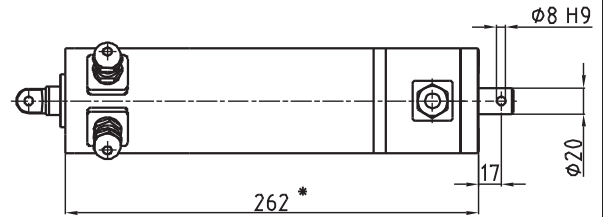

Brake and Encoder or
Brake and Potentiometer

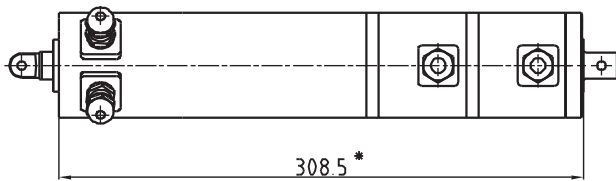

Brake and force dependent shut off

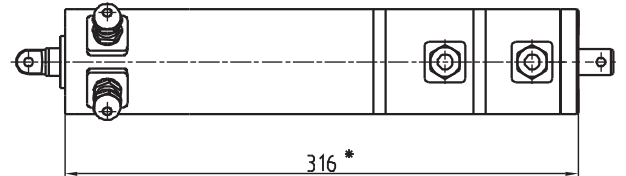

Dimensions connection heads

[mm]

Standard connection head

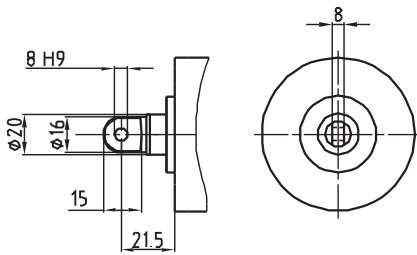

Without connection head

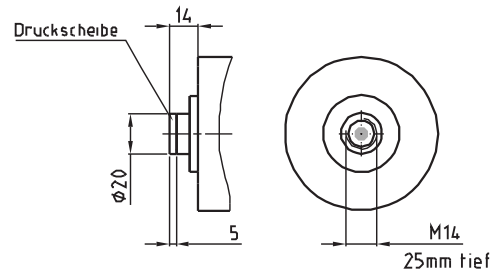

Adjustment ring

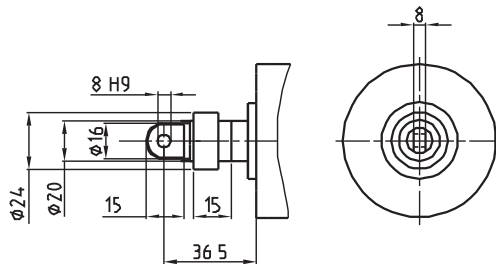

Adjustable connection head

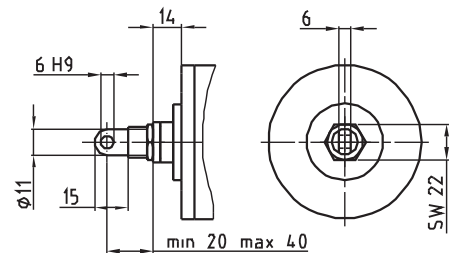

Subject to technical changes

Power tables

AC 3 x 230 / 400 V - 50 Hz

Motor speed min ⁻¹	Motor power kW	Duty cycle %	Planetary-gear	Trapezoidal-thread	Stroke speed mm/s	maximum Stroke force [N] at stroke length [mm]			
						100	150	200	250 300
1300	0,05	15	1:1	10x6 So	130*	200	200	200	200
1300	0,05	15	1:1	10x3 Sd	65*	280	280	280	280
1300	0,05	15	1:1	10x2 Sd	43*	310	310	310	310
1300	0,05	15	1-st.	10x6 So	30*	700	700	700	540
1300	0,05	15	1-st.	10x3 Sd	15	1000	1000	1000	540
1300	0,05	15	1-st.	10x2 Sd	10	1000	1000	1000	1000
1300	0,032	40	2-st.	10x6 So	7	1500	1500	1000	540
1300	0,032	40	2-st.	10x3 Sd	3	1500	1500	1000	540
1300	0,022	50-60	2-st.	10x2 Sd	2	1500	1500	1500	1000
1300	0,022	50-60	3-st.	10x6 So	1,5	1600	1600	1000	540
1300	0,022	50-60	3-st.	10x3 Sd	1	1600	1600	1000	540
1300	0,022	50-60	3-st.	10x2 Sd	0,5	1600	1600	1600	1000

AC 1 x 230 V - 50 Hz

Motor speed min ⁻¹	Motor power kW	Duty cycle %	Planetary-gear	Trapezoidal-thread	Stroke speed mm/s	maximum stroke force [N] at stroke length [mm]			
						100	150	200	250 300
1300	0,043	15	1:1	10x6 So	130*	120	120	120	120
1300	0,043	15	1:1	10x3 Sd	65*	170	170	170	170
1300	0,043	15	1:1	10x2 Sd	43*	190	190	190	190
1300	0,043	15	1-st.	10x6 So	30*	420	420	420	420
1300	0,043	15	1-st.	10x3 Sd	15	600	600	600	540
1300	0,043	15	1-st.	10x2 Sd	10	600	600	600	600
1300	0,032	15/40	2-st.	10x6 So	7	1500/900	1500/900	1000/600	540
1300	0,032	15/40	2-st.	10x3 Sd	3	1500/900	1500/900	1000/600	540
1300	0,022	15/50-60	2-st.	10x2 Sd	2	1500/900	1500/900	1500/900	1000
1300	0,022	15/50-60	3-st.	10x6 So	1,5	1600/960	1600/960	1000/600	540
1300	0,022	15/50-60	3-st.	10x3 Sd	1	1600/960	1600/960	1000/600	540
1300	0,022	15/50-60	3-st.	10x2 Sd	0,5	1600/960	1600/960	1600/960	1000

So = no self-locking; Ss = static self-locking; Sd = dynamic self-locking

1-stage = 4,3:1

2-stage = 18,9:1

3-stage = 82,3:1

* Starting at stroke speed of 20 mm/sec. a brake is requested.

Duty cycle applies to 10 min. duty time.

For tensile loading applies the maximum stroke force of the particular stroke speed.

Actuators with with single phase motors reach only 60% of the force and motor power of those with 3-phase motors and 15 % stated duty cycle.

The force and motor power stated at 40% and 60% won't change if the actuator is operated at 15% duty cycle.

Subject to technical changes

Spare parts list

AC 3x230V / 110V, transmission ratio 1:1

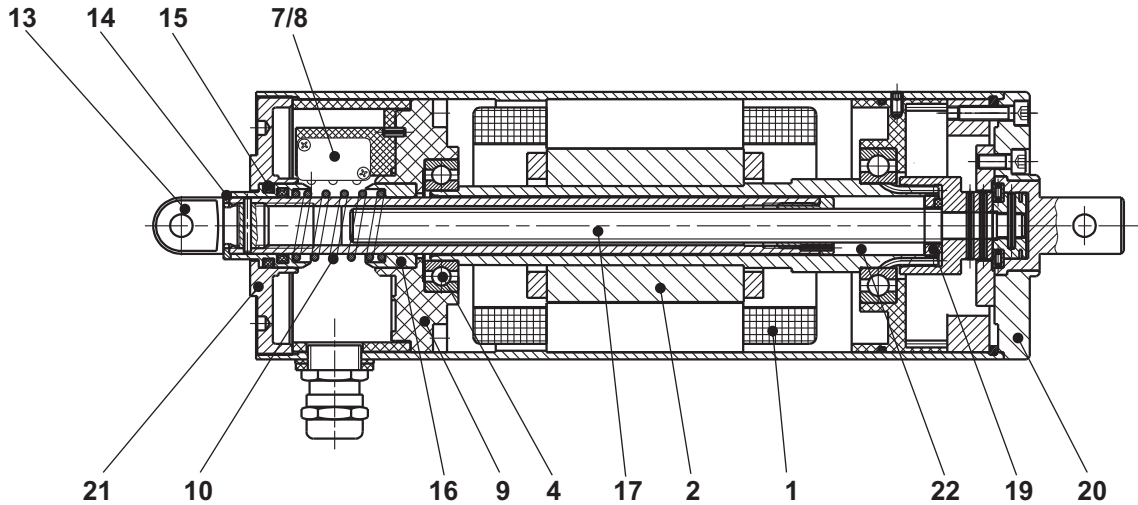

1-stage planetary gear

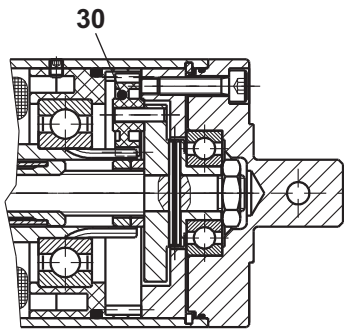

2-stage planetary gear

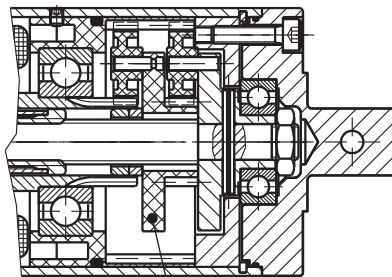

3-stage planetary gear

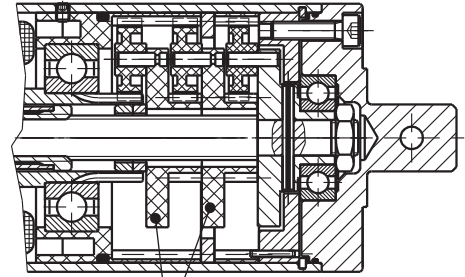

Item	Part name	Article-No.
1	Stator	Serial-No.
2	Rotor cpl.....	Serial-No.
4	Grooved ball bearing	00300100600483
7	Limit switch	02450100000600
8	Automatic disconnecter	02450100000250
9	Terminal board cpl.....	Serial-No.
10	Pressure spring	00155002470120
13	Connection head	Serial-No.
14	Pressure disc	Serial-No.
15	Switch jack 1 with quadrings	8-2001-01.05N
16	Switch jack 2	8-2001-01.06A
17	Spindle cpl.....	Serial-No.
19	Felt ring	8-2001-01.12
20	Gear cover	Serial-No.
21	Bearing plate	8-2001-01.08N
22	Spindlenut, piston tube	Serial-No.
30	Planet wheel	8-2001-130.04
31	Internal ring gear cpl.....	Serial-No.
33	Planet wheel carrier toothed	Serial-No.

Subject to technical changes

Spare parts list

Spring applied single disc brake

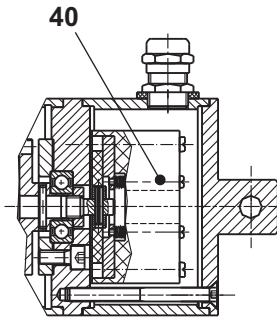

Force dependent shut off

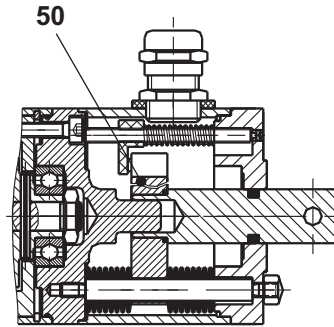

Potentiometer

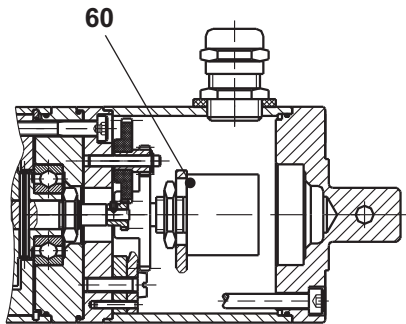

Encoder

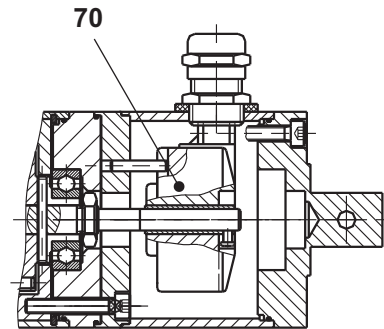

Item	Part name	Article-No.
40	Spring applied single disc brake	Serial-Nr.
50	Force dependent shut off	Serial-Nr.
60	Potentiometer	Serial-Nr.
70	Encoder	Serial-Nr.

Subject to technical changes