

(Translation)

Installation instructions



Subject to technical changes

Framo Morat GmbH & Co. KG
Höchst 7 • D-79871 Eisenbach

Tel.: +49 (0) 7657 / 88-0
Fax: +49 (0) 7657 / 88-333

www.framo-morat.com
info@framo-morat.com

Installation instructions (Translation)

1.0 Safety information

1.1 Warning notices

Signal words are meant to indicate danger, proscription or important informations. The following signal words are used:

Danger: DANGER indicates a hazardous situation which, if not avoided, will result in death or serious injury.



Warning: WARNING indicates a hazardous situation which, if not avoided, could result in death or serious injury.



Caution: CAUTION indicates a hazardous situation which, if not avoided, could result in minor or moderate injury.



Notice : NOTICE is used to address practices not related to personal injury.



For further visualisation we use the following symbols:



General Warning



Hot surfaces



Electrical dangers



Slip danger



Pending loads



Crush hazard



Environmental danger

The symbol indicates the type of danger, the signal word indicates the severity of the danger.

1.2 General safety notes

Before installation of the Framo Linear Actuator Mini Type 0 / 01 / 1 / 2 / 3 the following predictions have to be fulfilled, so that it can be assembled with other parts to a complete machine, without harming the security or health of persons.

- Every linear actuator is shipped with the installation instruction and the circuit diagram. These are taped to the drive in an envelope. Installation without this documentation is forbidden. Unintended or inappropriate use leads to the loss of any liability claim. This installation instruction and the annexed declaration of incorporation have to be attached to the Framo drive until it is assembled into a complete machine and become by then a part of the technical documentation of the complete machine.
- Before installation and operation read all documents carefully and follow all instructions.
- The abidance of basic safety- and health protection requirements is considered by application of accredited engineer standards during design and is approved by the declaration of incorporation.
- The mechanical and electrical installation as well as the adjustment and setup has to be done by certified electricians, authorized by responsible authority.
- Doublecheck the technical data on the name plate and follow the instructions on the labels of the drive.





• Moving parts have to be secured against unintentional contact to avoid injuries. The manufacturer points out that this is the responsibility of the user.



- Don't modify the drive. Modifying the drive is dangerous and voids the warranty.
- Don't block the drive while operating. This may cause hazard to persons and/or property and may damage the drive seriously.
- Don't overload the drive. The values for stroke force, voltage and duty cycle declared on the name plate can't be exceeded. Non-observance may cause danger to persons and property and the drive may be damaged seriously.



- Make sure that power is disconnected before working on the wiring. Secure the power source against unintentional switch on.
- Connect the drive only to a power source with ground terminal.
- Pay attention to the appropriate circuit diagram (schematic).



• Don't touch the drive during operation. The housing temperature can rise up to 90°C (close to 200°F).

1.3 Conditions of use

Framo linear actuators are drive systems, solely determined to drive machines, devices and equipment that exclude direct or indirect hazards to persons. If hazards to persons can't be excluded, it is obligatory to build additional devices (e.g. cover, shut off, cutting unit) to exclude the risk. As long as this additional device is not attached it is forbidden to use our drive.

We refer users of gear motors to safety rules, regulations and laws governing the protection of staff working in the area of moving equipment. Protective guards or barriers shall be used. Similarly-protective measures are required where suspended loads are involved.

Keep in mind the common due diligence in connection with technical products to avoid further hazards.



Attention Danger!

Applications intended for the transport of passengers are not permissible!



Attention Notice!

If our product optionally allows such an application, has to be clarified with the manufacturer in advance.



Attention Caution!

By default our gear motors are intended for environmental temperature from 0°C up to 60°C, and a duty cycle of up to 60%. The protection class is IP54. Optional variances are noted on the name plate.



Attention Danger

Generally the drive is not for use in dangerous explosive areas.

Exception (not standard): Drives with the following characterization (on the name plate) can be used (exclusively) in the named zone.

EEx II 3D,  bck II T5

Please note: This application has to be confirmed with an added special confirmation.

2.0 Transport, Setup and Installation

2.1 Transport



Attention Caution!

Wear safety-shoes while carrying and working on/with the drive. A falling drive may cause injuries. Use a solid packaging to transport the drive to the installation-site.

2.2 Setup and Installation

Mount the drive without tensioning. Attaching parts must not be mounted by hammering.

2.3 Fastening torque for mounting screws



Attention Warning

The property class for the mounting screws has to be 8.8 or better. Use the following table for correct fastening torques and screw-in depth.

Type	Screw	Fastening torque	Min. screw-in depth	Max. screw-in depth
Mini 0	2 x M6	8 Nm	8 mm	12 mm
Mini 01	2 x M8	14 Nm	12 mm	16 mm
Mini 1	2 x M12	30 Nm	18 mm	24 mm
Mini 2	2 x M12	30 Nm	18 mm	24 mm
Mini 3	2 x M20	70 Nm	30 mm	40 mm

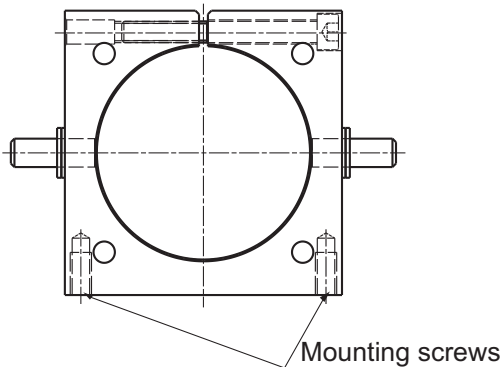

2.4 Fastening torque for the clamping flange

While adjusting the clamping flange (fastening D,E,F) regard the following fastening torques.

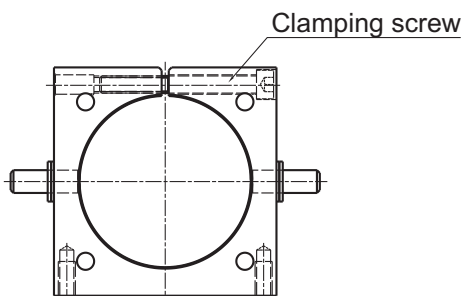

Type	Screw	Fastening torque
Mini 0	1 x M6	6 Nm
Mini 01	1 x M8	10 Nm
Mini 1	1 x M12	25 Nm
Mini 2	2 x M12	55 Nm
Mini 3	2 x M16	110 Nm

Subject to technical changes

3.0 Electrical Installation



Attention Danger!

- Make sure to interrupt the current supply before working on the wiring and secure it against unintentional switch on.
- Connect the drive only to a power source with ground terminal.
- Read the circuit diagram carefully and pay attention to use the right voltage (see name plate on drive)
- Connect all external control- and power supplies according to circuit diagram. If limit switches and/or thermal protection are not connected the drive can be destroyed. The thermal sensor (bimetal) is an NC contact (normally closed) and shall interrupt the motor power if activated.



Attention Danger!

Protect the motor against unintentional start, because the thermal switch automatically closes the contact after cooling down (bi-metal contact).

- Confirm that the direction of the drive corresponds with the dedicated limit switches (see adjustment instructions).



Attention Notice!

Don't decelerate the motor by reversing the motor power. The life of the gear motor will be dramatically reduced.

4.0 Important informations

4.1 Duty cycle

The duty cycle reference time is 10 minutes in a max. ambient temperature 40°C at an altitude of 1000 meters.

4.2 Ambient temperature, water condensation



Attention Notice!

Consult the manufacturer for operation under 0°C (to select a suitable gear lubrication). Permanently changing temperatures or high humidity can lead to water condensation. For proof we offer optional versions (condensed water drain holes or moisture protection varnish coat for rotor and stator).



Attention Warning!

The drain holes will effect the standard protection class (IP54).

4.3 Operating temperature



Attention Warning!

If the temperature of the drive, in spite of approved usage, exceeds 90°C, refer to the manufacturer. Perhaps there's a defect.

4.4 Oil leaks



Use extra caution if the gear motor is leaking oil.
The surface might be slippery.



Under these circumstances environmentally detractions are possible.

4.5 Self-locking



Attention Notice!

Self-locking is affected by lead angle, face surface roughness, running speed, lubricant and temperature rise. A distinction must be made between dynamic (from motion) and static (standstill) self-locking.

Shaking or vibration can annul the self-locking.

Similarly a number of factors associated with lubrication, running speed and load can favour slip characteristics to such an extent that self-locking is counteracted.

This means that gearing which is self-locking in theory is no substitute for a brake or reverse lock. Therefore it is impossible for us to accept warranty obligations in respect of self-locking.



Attention Danger!

Important: Self-locking can NOT be responsible for safety characteristics!

5.0 Warranty, maintenance, approved usage

The drive is maintenance free due to lifetime-lubrication.

The lifetime of the drive depends on the application (eg. ambient temperature, torque, speed, cycles, environmental influences). The piston tube should be cleaned from time to time with an oiled cloth because dirt and deposit on the piston tube can disturb the correct function of the limit switches

6.0 Warranty and repair

All drives are tested before delivery. During warranty-time the drive shall not be opened. Dismantling leads to expiration of any warranty by the manufacturer.

If a drive has to be repaired send it back to the manufacturer or a suitable agency. A service technician can be ordered for on-site service on short notice.

7.0 End of product life-time:

7.1 When the indicated lifetime is reached you can send the drive back for overhaul.

7.2 If you want to dispose the drive please pay attention to ecological and legal regulations.

8.0 Service

To offer fast and competent help to our customers - e.g. while installation - we provide a service-number.

Under +49 (0)160 / 941 84 444 you can reach the 24 hour hotline. Please note that the usual fee will arise.